



佛山市南海大昌货架有限公司
佛山市南海大昌钢构有限公司

货架厂地址: 广东省佛山市南海区大沥广佛公路谢边段(机场路口)
 钢构厂地址: 广东省佛山市南海区大沥桂丹路谢叠大桥侧
 电话:(0757)81185133 85561031 85553056
 业务电话:(0)13924842633 (0)13902410873 (0)13902413538
 E-mail:dachanghuojia@hotmail.com
<http://www.dcshef.com> 大昌货架有限公司
<http://www.dcsteels.com> 大昌钢构有限公司
<http://www.dcshef.com.hk> 香港大昌贸易有限公司

Dachang Racking & Shelving Co.,Ltd. Nanhai, Foshan
 Dachang Steel Structure Co., Ltd.Nanhai,Foshan
 Add-1:Xiebian,Dali,Nanhai District,Foshan City,Guangdong Province
 Add-2:Xiedie Bridge,Guidan Road,Dali,Nanhai District,Foshan City,Guangdong Province
 Tel:(0757)81185133 85561031 85553056
 Mobile:(0)13924842633 (0)13902410873 (0)13902413538
 E-mail:dachanghuojia@hotmail.com
<http://www.dcshef.com>
<http://www.dcsteels.com>
<http://www.dcshef.com.hk>

自动立体仓库系统货架 Automated Storage Retrieval System AS/RS



2021-06
佛山市南海大昌货架有限公司
 Dachang Racking & Shelving Co.,Ltd. Nanhai, Foshan
佛山市南海大昌钢构有限公司
 Dachang Steel Structure Co., Ltd.Nanhai,Foshan

ISO质量体系认证企业
佛山市名优企业
 The ISO quality system certified enterprise
 Foshan city famous enterprises



企业简介 Company Profile

ISO质量体系认证企业
佛山市名优企业
The ISO quality system certified enterprise
Foshan city famous enterprises

广东省佛山市南海大昌货架有限公司始建于1987年，专业从事设计、制造及安装大、中、重型货架以及物流配套产品生产的厂家。

公司拥有占地面积10万平方米的高科技配置厂房，位于广佛公路谢边段与佛山机场路交界处，周边有铁路、高速公路、河港以及机场，交通运输十分方便，周围公共设施齐备。经过30多年的发展，公司拥有一批基础扎实、素质较高的生产技术人员与专业设计人员，是广东省最具规模、设备先进的外向型货架生产基地。以“质量与用户同步，服务使用户满意”为目标，积极推动和实施ISO9001:2008质量管理体系，对工程设计、产品生产、检验、施工及安全服务实行严格控制和管理。在全国各地均设有分销机构，60%产品远销国外，深得中外用户的信赖，多次荣获“名优企业”和“合同守信用企业”称号。

本公司的产品面向各大工厂、工矿、机场及物流配送等单位。经过不断完善的设计制造，拥有组装式、整体式货架合一产品系列，其中仓库型货架高度可达30米。以一流的服务、一流的品质满足客户的需求是我们不断追求的目标。

Dachang Racking & Shelving Co., Ltd. Nanhai, established in 1987, specializes in designing, manufacturing and installing industrial & commercial large, medium and heavy-duty shelving and racking products, and also accessories. In 2008.

The company operates 100,000 square meters of high tech equipped workshop, located at the junction of the section of Xiebian of Guang-Fo highway (No.325 Highway) to Foshan Airport Road. We are surrounded by the networks of railway, freeway, river port and airport, enjoying very convenient facilities of communication and transportation. After more than 30 years of development, the enterprise has now become one of the leading manufacturers in China and the most sizable racking and shelving company in Guangdong, with a group of senior engineers, professional designers and technical personnel, fulfilling ISO9001:2000 certificated quality standards, controlling and administering strictly the engineering design, production, inspection, construction and safe service. We have distributors all over the country and 60% of our products are exported overseas. We adhere to the target of ensuring the quality requirements and service level that is most satisfying to our international clients. This resolve has earned for us many accolades such as the titles of "Famous enterprise" and "Contract trustworthy enterprise" among others.

We supply our products to factories, mining, airports and logistics distribution. We always continue improving the design and production and we produce the series of assembly shelves, integral and multi shelves. We are able to produce the warehouse shelves with a height of 30 meters. We insist on this target: by perfect products, sincere service and a great reputation, by the technological power, advanced equipment and excellent skills, to earn the confidence from customers all over the world.

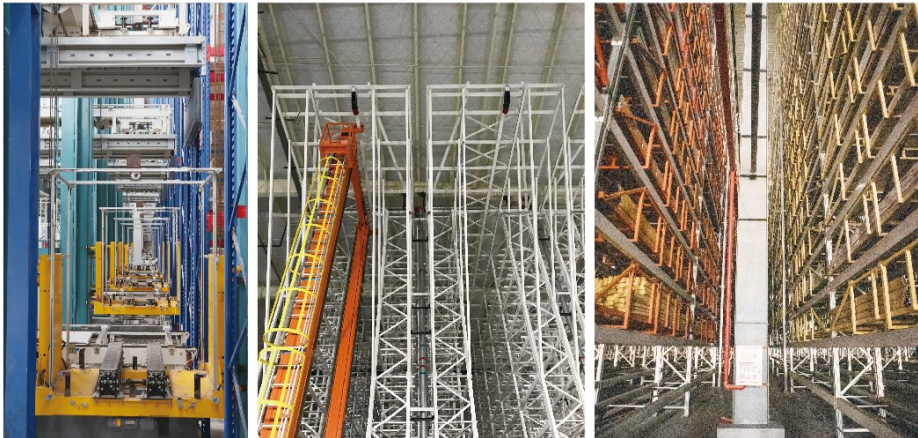

FSL
佛山照明

新河铝材
Xinhe Aluminium

全面使用大昌货架自动仓库货架
Fully use the shelves of automatic warehouse in Dachang

佛山市南海大昌货架有限公司 Dachang Racking & Shelving Co.,Ltd. Nanhai, Foshan

大昌货架
DACHANG SHELVING



自动立体仓库货架

Automated Storage/Retrieval System,AS/RS

佛山市南海大昌货架有限公司 Dachang Racking & Shelving Co.,Ltd. Nanhai, Foshan

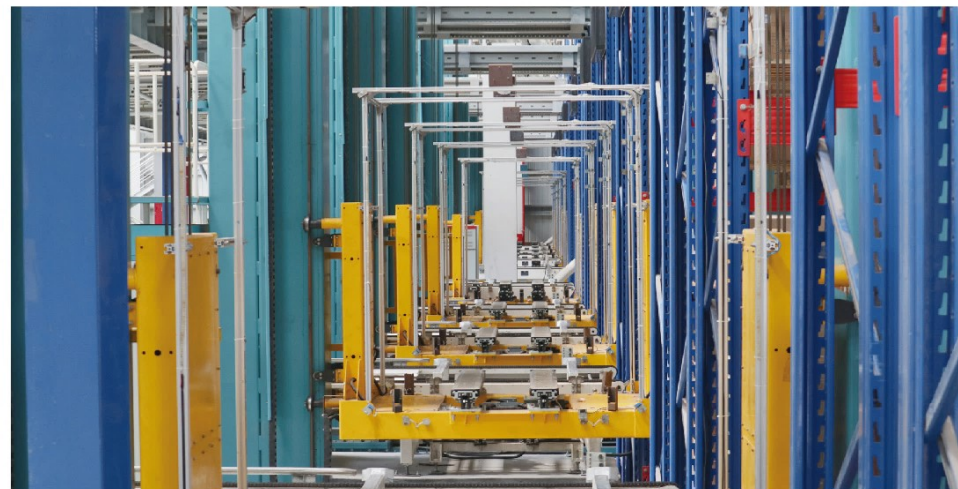
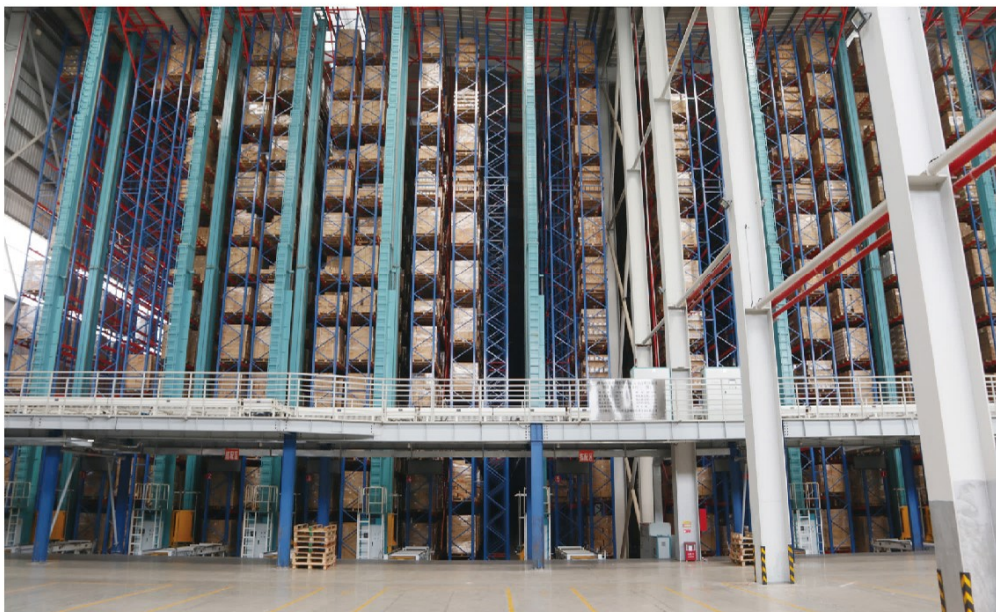

自动立体仓库货架

Automated Storage/Retrieval System,AS/RS

佛山市南海大昌货架有限公司 Dachang Racking & Shelving Co.,Ltd. Nanhai, Foshan





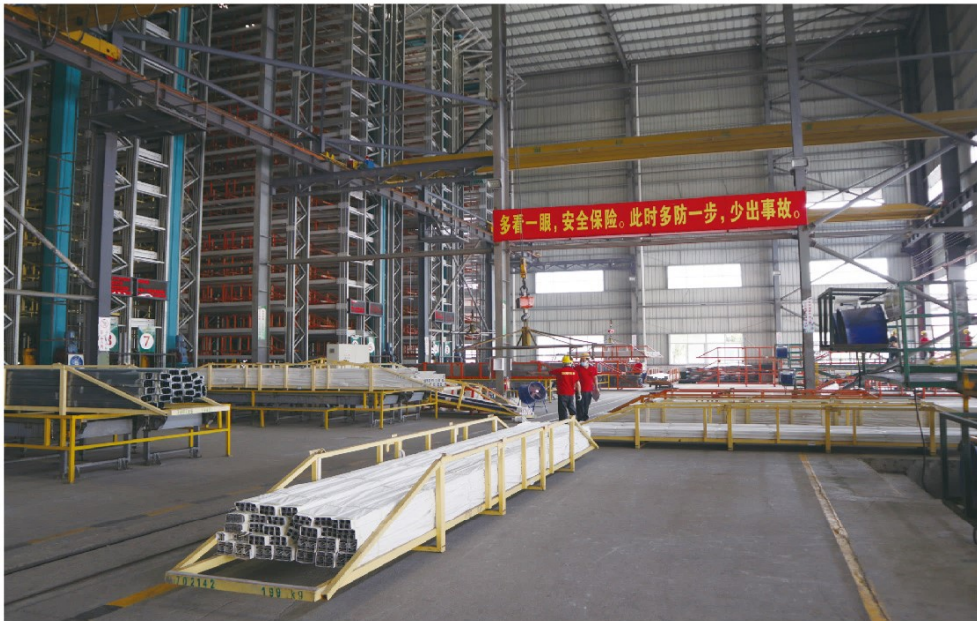

自动立体仓库货架

Automated Storage/Retrieval System,AS/RS

佛山市南海大昌货架有限公司 Dachang Racking & Shelving Co.,Ltd. Nanhai, Foshan

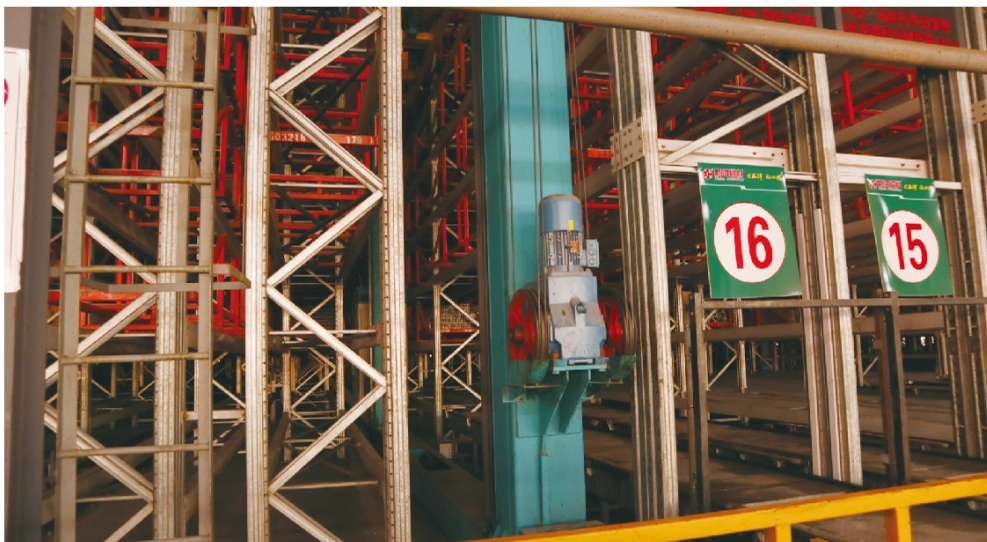

科学设计，先进加工技术，精心安装施工，为数码立体自动仓库系统提供有效质量保证。

The scientific design, advanced processing technology and careful installation ensure the quality of Automated Storage/Retrieval System,AS/RS.

自动立体仓库货架

Automated Storage/Retrieval System,AS/RS

雄厚技术人才，丰富生产经验，认真负责工作态度，成为优质货架正能量。基础扎实、素质优良和专业设计队伍，严格规范检测制度和先进设备与世界同步。

Strong technical talent, rich production experience, serious and responsible attitude of working are positive energy for supplying high-quality shelf. A solid foundation of good quality and professional design team, strict inspection system and advanced equipment are synchronizing with the level of the world.



佛山市南海大昌货架有限公司 Dachang Racking & Shelving Co.,Ltd. Nanhai, Foshan



大跨越、大发展、大货架，大昌货架伴随时代进步努力为大型优质企业提供良好自动仓库系统。现场实景为华南地区大跨度高层自动全数码快速配送物流中心。

Wide span, great development, big rack, Dachang shelves developing together with the progress of the times strive to provide good quality Automated Storage/Retrieval System,AS/RS for large-scale enterprises. The scene shows the large-span high-rise automatic digital quick distribution and logistics center of Southern China.



自动立体仓库货架

Automated Storage/Retrieval System,AS/RS

佛山市南海大昌货架有限公司 Dachang Racking & Shelving Co.,Ltd. Nanhai, Foshan

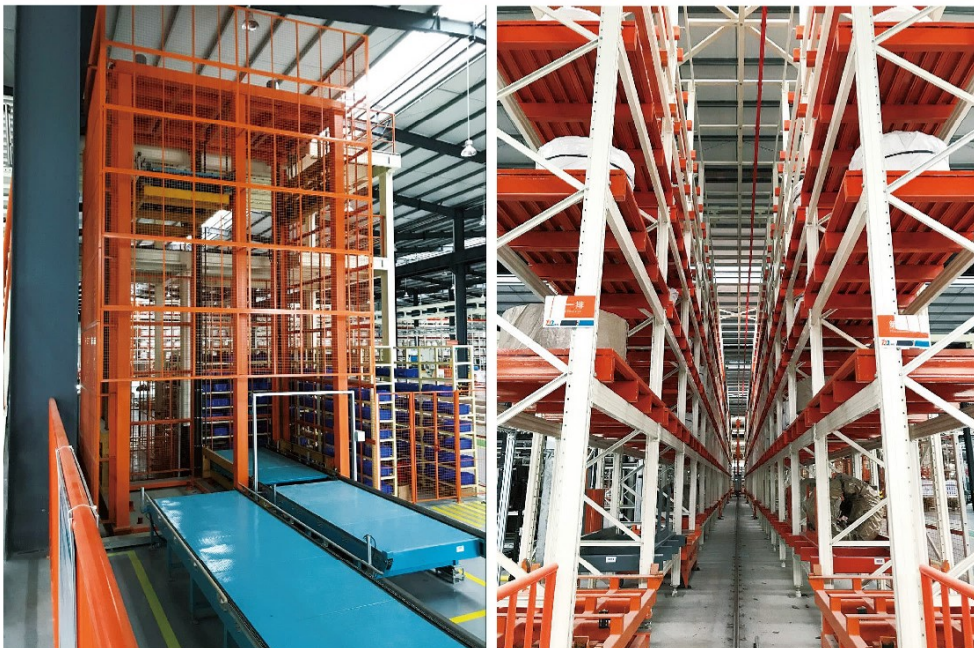
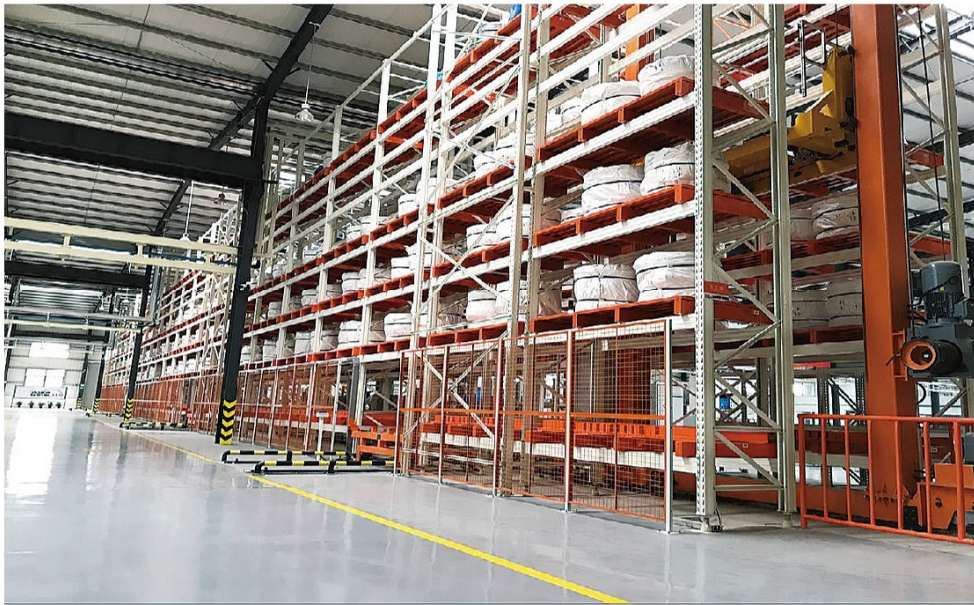

广东温氏集团新兴南牧机械有限公司仓库货架由大昌公司承建

广东温氏集团新兴南牧机械有限公司仓库货架由大昌公司承建

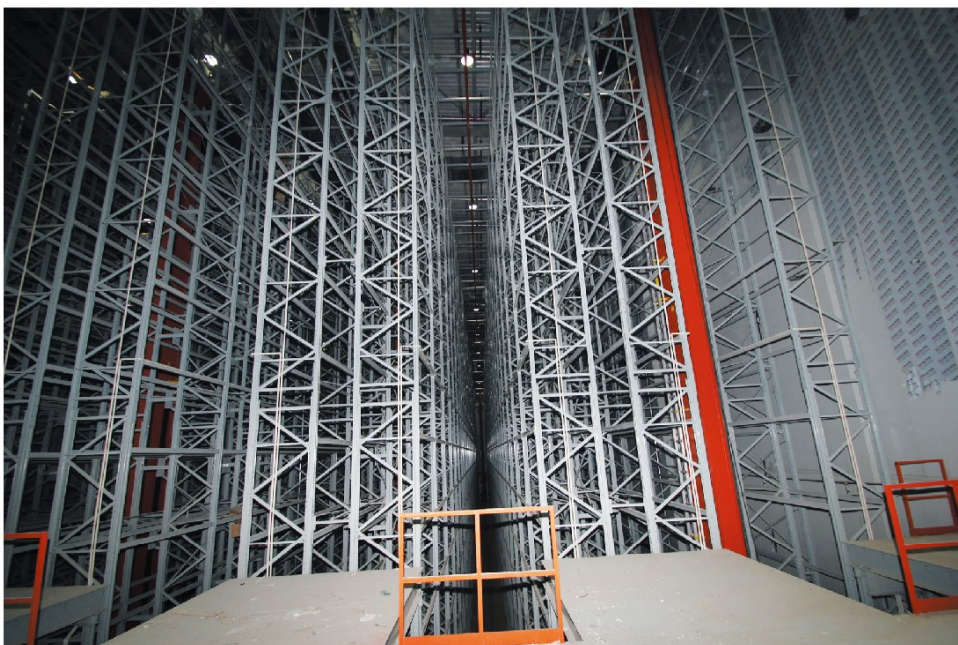

大型堆垛机、大型货架以及大容量电脑处理器为自动仓库系统提供良好坚实的基础，为企业带来显著经济效益。

Large-scale stacker, large-scale shelves and high capacity computer processor ensure a solid base for Automated Storage/Retrieval System,AS/RS, which bring notable economic benefits to enterprises that use it .



自动立体仓库货架

Automated Storage/Retrieval System,AS/RS

佛山市南海大昌货架有限公司 Dachang Racking & Shelving Co.,Ltd. Nanhai, Foshan



大型智能设备，大跨度长8M，高19M立体自动仓库货架。从设计到生产，标志着华南地区立体自动仓库货架走向新的里程碑。

Large-scale stacker, large-scale shelves and high capacity computer processor ensure a solid base for Automated Storage/Retrieval System,AS/RS, which bring notable economic benefits to enterprises that use it .

地基实拍图





现场实景图

大型铝材生产企业模具自动化仓库管理系统，节省时间，数据处理准确，对提高生产力和企业腾飞起到积极作用。

Picture of scene

Automatic warehouse management system of mold of large-scale factory of aluminum, which can save time and process data exactly. Its superiority promotes the advance of productive ability and rapid development of the enterprise.

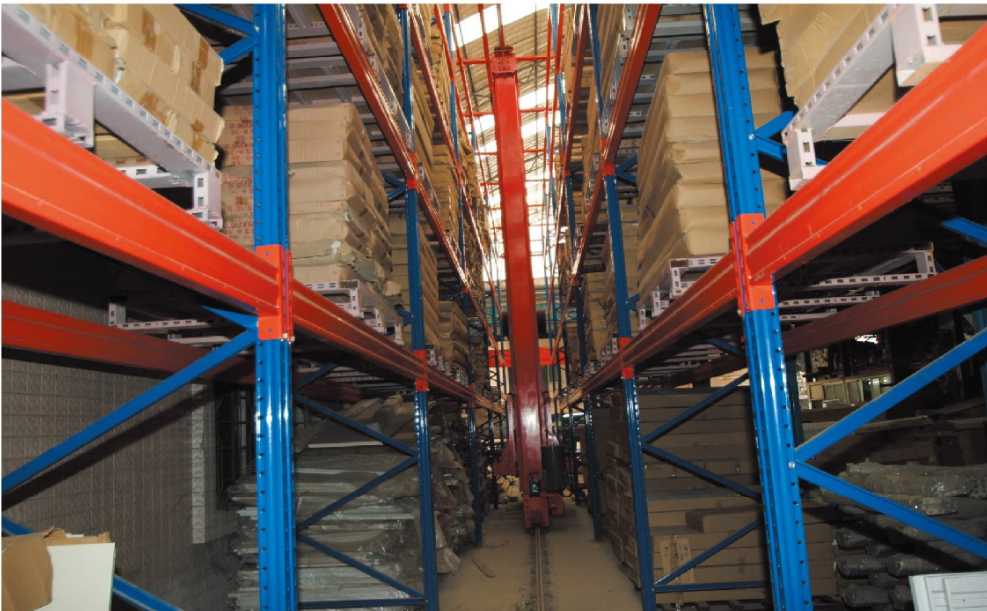

一、堆垛机主要配置 Main configuration of stacker

主要电器元件 Main electrical parts	品牌 Brand
行走电机减速机 Travel motor reducer	SEW SEW
升降电机减速机 The lifting motor reducer	SEW SEW
PLC PLC	西门子 Siemens
操作界面 The operation interface	西门子 Siemens
变频器 Frequency converter	西门子或安川 Siemens or Yaskawa
光电开关 The photoelectric switch	劳易测或倍加福 Leuze or Pepperl + Fuchs
低压电器 Low voltage electrical apparatus	施耐德 Schneider

二、堆垛机主要技术与参数 The main technical performances and parameters

额定起升重量 Lifter weight rated	双立柱 Double column	单立柱 Single column
托盘尺寸 Tray size	0.8; 1.0; 1.5; 1.7; 2.0; 2.5; 3.0...	0.1; 0.25; 0.5; 0.8; 1.0; 1.5...
货叉类型 Fork type	800*1000; 800*1200; 1000*1200或任意 800*1000; 800*1200; 1000*1200 or any other	800*1000; 800*1200; 1000*1200或任意 800*1000; 800*1200; 1000*1200 or any other
运行速度 Fork speed	单货叉; 双货叉或以上 Single fork; double fork or more	单货叉; 双货叉 Single fork; double fork
起升速度 Running speed	5---200m/min (变频调速) 5---200m/min (VVVF)	5---180 m/min (变频调速) 5---180 m/min (VVVF)
货叉速度 The lifting speed	2/12, 4/16, 5/20(双速)或者变频调速3---60 m/min 2/12, 4/16, 5/20 (double speed) or variable frequency drive 3---60 m/min	2/12, 4/16(双速) 或者变频调速3---60m/min 2/12, 4/16(double speed) or variable frequency drive 3---60m/min
总功率 Fork power	3---40 m/min (变频调速) 3---40 m/min (VVVF)	3---40 m/min (变频调速) 3---40 m/min (VVVF)
整机全高 The total power	>20kw	>20kw
最低货位标高 The height of whole machine	3<h<25m	3<h<25m
最高货位标高 The elevation of the lowest position	>560mm	>560mm
导电方式 The elevation of the highest position	<23 m	<23 m
通讯方式 Conducting mode	滑触线 Sliding contact line	滑触线 Sliding contact line
控制方式 Communication mode	总线通讯; 工业无线以太网 Profibus; Industrial Wireless Ethernet	总线通讯; 工业无线以太网 Profibus; Industrial Wireless Ethernet
出入库作业方式 Control mode	手动; 半自动; 单机自动; 联机自动 Manual; semiautomatic; single machine automatic; on-line automatic	手动; 半自动; 单机自动; 联机自动 Manual; semiautomatic; single machine automatic; on-line automatic
	拣选式; 单元式; 混合式; 组合式 The chosen type; cell type; hybrid; combine type	拣选式; 单元式; 混合式; 组合式 The chosen type; cell type; hybrid; combine type

穿梭车系列

The shuttle

佛山市南海大昌货架有限公司 Dachang Racking & Shelving Co.,Ltd. Nanhai, Foshan



穿梭母车 Shuttle carrier

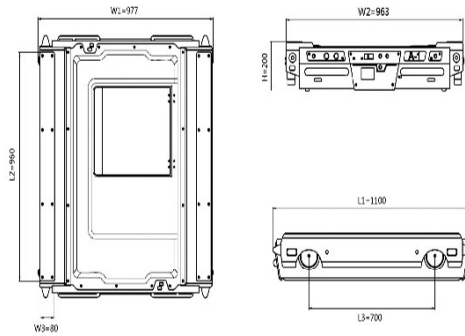

Non-standard model L1=1300mm, L2=1160mm, used for non-standard long pallet L1200*W1200

穿梭子车 Radio shuttle

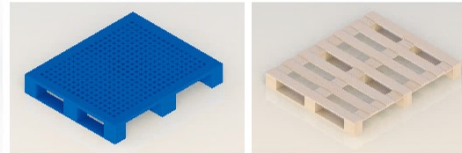

塑胶托盘 Plastic tray 木托盘 Wooden pallets

入口托盘升降机 Inbound lifter for pallets

穿层式往复升降机 Reciprocating lifter enter different storey
◆ 实现双轨搬运小车及承载货物的不同轨道高度的切换;
To realize the transfer of the shuttle and carried cargo vertically enter rails of different heights;
◆ 可以实现多种高度的轨道在同一垂直空间内的交叉输送;
To realize the crossing conveyance vertically enter rails of different heights.

输送方式 Transportation mode

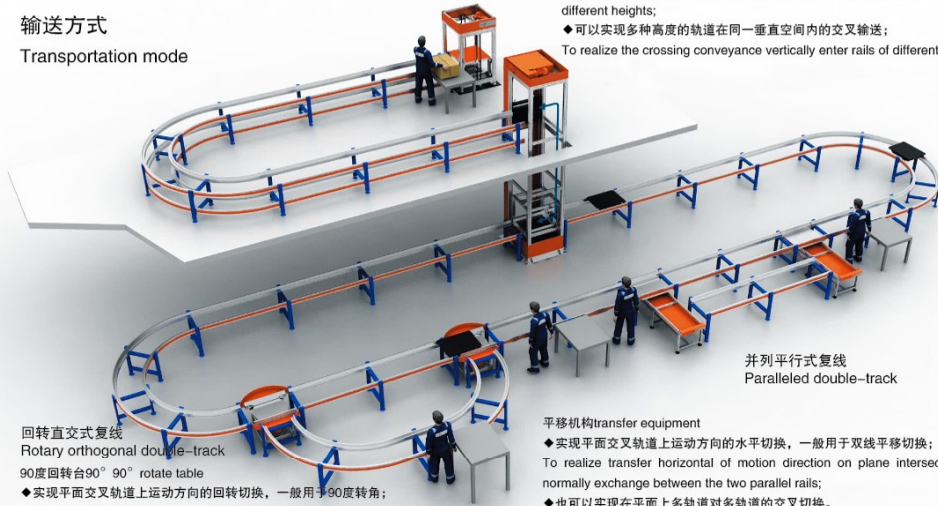

并列平行式复线
Paralleled double-track

回转直交式复线
Rotary orthogonal double-track
90度回转台 90° rotate table
◆ 实现平面交叉轨道上运动方向的回转切换，一般用于90度转角;
To realize the rotary transfer of the motion direction on the plane intersecting orbit, normally used
◆ 也可以实现在平面上多交叉轨道的多方向转换;
Also to realize crossing transfer horizontal between intersecting rails.

平移机构 transfer equipment
◆ 实现平面交叉轨道上运动方向的水平切换，一般用于双线平移切换;
To realize transfer horizontal of motion direction on plane intersecting orbit, normally exchange between the two parallel rails;
◆ 也可以实现在平面上多轨道对多轨道的交叉切换。
Also to realize the crossing transmission horizontal between multi parallel rails.

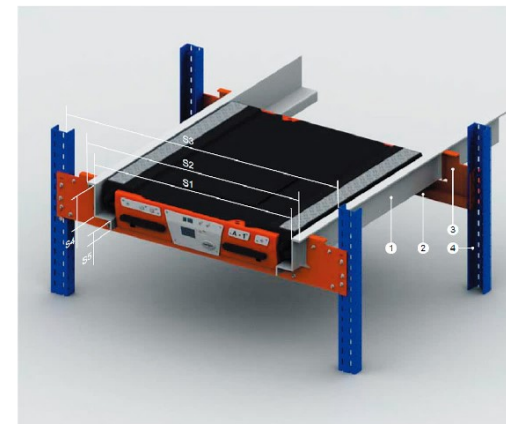

自动穿梭车工程实例展示 Scene of project of automatic shuttle



单侧进出模式简图 Rails in the middle of racking

◆ 子母车及轨道布置在穿梭式货架的中间位置:

The shuttle carrier system and guide rail are arranged in the middle of racking;

◆ 入库、出库各配置一套提升与输送系统:

Loading section and unloading section are equipped respectively with elevating and conveyor system;

◆ 出入库方式: 均在一侧;

Access of goods: loading/unloading both in one side;

◆ 出入库模式: 单巷道内, 后入先出模式 (LIFO)

Mode of loading and unloading: last-in-first-out (LIFO) in single channel;

◆ 整体库区, 以巷道为单元, 自由存取;

The whole warehouse consists of many channels, goods are loaded and unloaded freely;

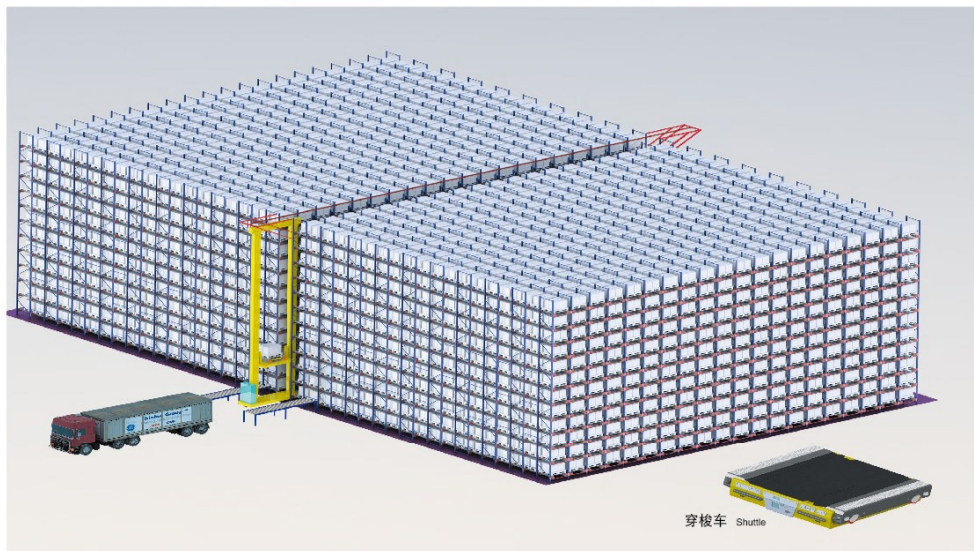

穿梭车 Shuttle



应用场合 Usage occasion

◆ 自动化物流输送 Automatic conveyor

◆ 适用车间至仓库间的、长距离的往返物流输送;

Suitable to longest distance and round-trip conveyor between the warehouses and workshop;

◆ 半自动化装配与物流输送组合 Combination of semi-automatic assembling and logistics conveyor

通过对小车安装底板的专用化改造, 可适用于各种半自动化的工装板方式环形装配线, 以及装配半成品缓存、在线测试、至仓库间的循环输送;

By special modification for the baseboard of auto cruisers shuttle, it could be used in semi-automatic annular assemble lines with baseboard in many occasions, finished product buffer on-line, testing on-line, conveyor between each warehouses or workshops etc.;

系统特点 Features

◆ 模块化 Modularization

搬运小车、各工位单机, 全采用模块化搭建, 可实现多种方式组合, 更改更方便快捷、成本更低;

Automatic-guided vehicle and every unit are modularly constructed which can realize multiple combination, enjoying more convenient and efficient with lower cost;

◆ 柔性化 Flexibility

双轨搬运小车采用电池或刷电, 可随意移动, 所有单机相对独立, 并采用无线进行操作与控制, 整个系统更柔性化;

The automatic-guided vehicle is driven by batteries and brush motors, which can move freely, every unit is independent, which can realize wireless control and dispatch, making entire system more flexible;







(实景) 日产汽车配送中心,使用大昌阁楼式货架。
Dachang mezzanine storage built in Nissan motor's 4S shop.

◆ 楼板式样 Flooring grates

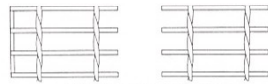

材料轻,采光,换气性好

◆ 花纹钢板

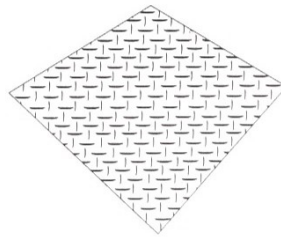

防滑



(实景) 日产汽车配送中心,使用大昌阁楼式货架。
Dachang mezzanine storage built in Nissan motor's 4S shop.



立柱截面图 The column section

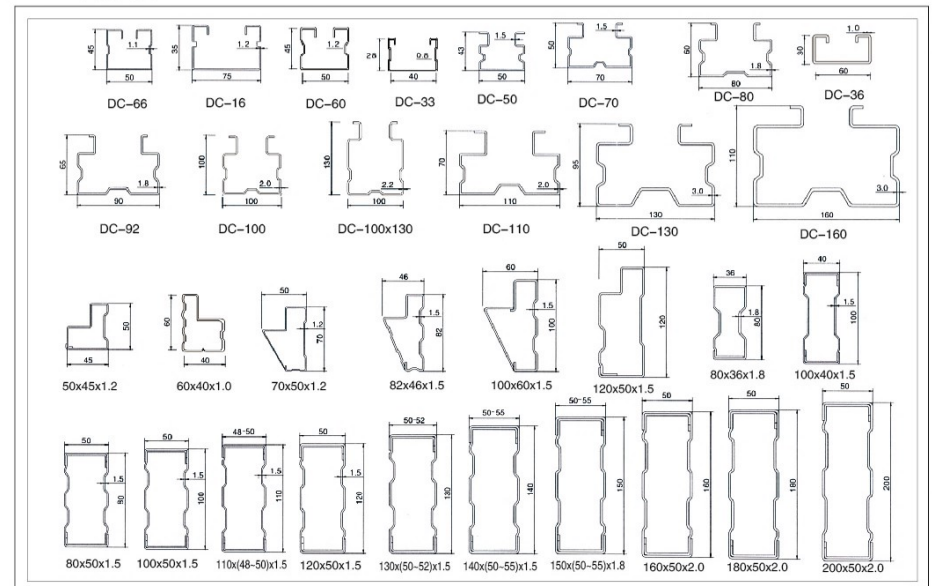

通廊式仓库货架

Drive-in/Drive-through Racks

大跨度通廊式货架专为外国企业设计，我们以先进科学设计为导向和成功的生产工艺，赢得外国企业家的认可和 使用,并得到一致好评。

Both drive-in and drive through systems are the ultimate in high-density storage.No other form provides more storage capacity per square foot of room than these systems.They provide a very low cost yet efficient means of high volume storage.



通廊式仓库货架导轨
Roll formed pallet rail



通廊式仓库货架

Drive-in/Drive-through Racks



悬臂式仓库货架

Cantilever Storage



结构坚固，安装方便，使用灵活，它具备对货物迅速储存配送等特有结构的优点。

Cantilever racks are great to organize a warehouse,lumber yard or manufacturing facility.With cantilever racks,each type of product can ben segregated by commodity and size,increase labor efficiency,reduce in injury.

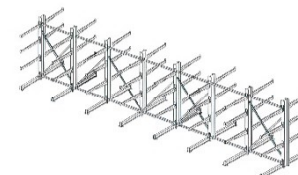
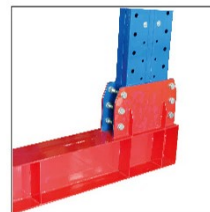

悬臂式货架(1000Kg/支臂)
Powder coated light duty
cantilever racks for indoor use.



坚美公司悬臂式货架应用实景拍摄(1000KG/支臂)
JIANMEI Cantilever Rack
双面高达8000mm Double up to 8000mm



广州阿波罗公司悬臂式货架应用实景拍摄(1000KG/支臂)
Cantilever system in Guangzhou Apollo

铝型材专用货架

Special shelf for aluminum profile

佛山市南海大昌货架有限公司 Dachang Racking & Shelving Co.,Ltd. Nanhai, Foshan

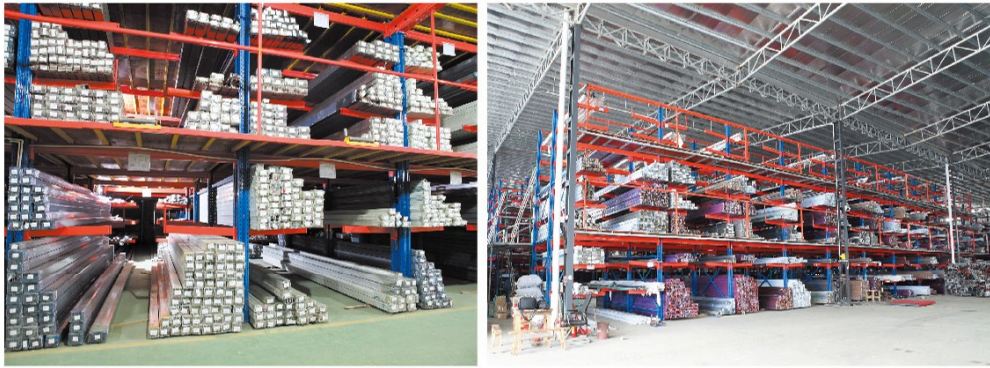

自动仓库托盘、周转笼

Automatic warehouse pallet, turnover cage

佛山市南海大昌货架有限公司 Dachang Racking & Shelving Co.,Ltd. Nanhai, Foshan



周转笼A-1
Turnover cage



周转笼A-2 (布匹专用)
Turnover cage



自动仓托盘A Floor slab



自动仓托盘B Floor slab



自动仓托盘C Floor slab

